



## TiF-DP. Femtosecond Ti:Sapphire Laser with Direct Diode Pumping

- Integrated diode pump source with control unit
- Tuning range 760-840 nm
- Pulse duration <20 fs
- Output power up to 200 mW
- Thermally stabilized monolithic body
- Integrated spectrometer and power meter (optional)
- Fully remote laser output control (optional)
- Automatic mode-locking and power stability locking (optional)



The TiF-DP-30 femtosecond laser system with on-board pump source

### Product overview

The novel TiF-DP system is a Ti:Sapphire femtosecond laser oscillator having its active medium directly pumped by emission from a laser diode assembly. Such architecture leads to significant cost reduction while system still maintains the output beam quality, pulse duration and long-term output power stability of conventional DPSS-laser-pumped systems. Average output power reaches 200 mW and is sufficient enough to use the TiF-DP series systems as a seed laser source for amplifier systems with enough headroom, as well as implement it in numerous scientific research applications. The laser design features a rigid monolithic thermally stabilized body and ensures long-term output power stability drift below 0.5% rms.

The laser system may be factory-optimized for any of the three main output pulse duration choices: 20, 30 or 50 fs (with 100 fs by special request). The general rule is that accessible values of output power and tuning range width increase with longer output pulse duration.

There are two pre-designed factory supply packages:

- the "Basic" factory package includes a simple USB motorized wavelength tuning slit and a push-button non-automatic electric starter. Wavelength tuning and calibration with this package is done via step number information in basic Windows software.

- the "Auto" factory package includes built-in spectrometer and power meter, single-touch wavelength tuning with presets, configurable widget software, active power lock function and automatic mode-lock start and monitoring. With this package the system boasts exceptional long-term stability and longer uninterrupted runtime.

An external prism pair or a tunable pulse compressor (the APC Kit or APC Pro units) for dispersion pre-compensation is also available.

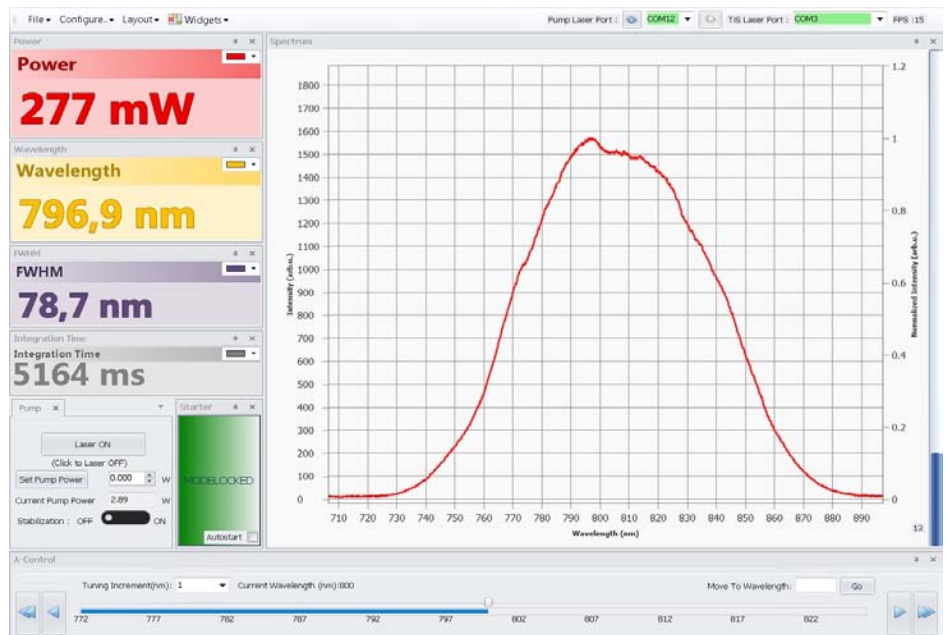

Widget-based software screenshot for the TiF family of lasers with integrated spectrometer ("Auto" package)

Possible applications of the TiF Series lasers:

- Multiphoton microscopy
- Seed oscillator for amplifier systems
- Terahertz generation
- "Pump-probe" spectroscopy
- Material processing
- Optical coherent tomography
- Semiconductor Device Characterization
- Fundamental Research



**AVESTA**  
LASERS AND OPTICAL SYSTEMS



Avesta Ltd., 11 Fizicheskaya Street  
Troitsk, 108840, Moscow, Russia  
Tel.: +7 (495) 967-94-73  
Fax: +7 (495) 646-04-95

fs@avesta.ru  
www.avesta.ru

	TiF-DP-20	TiF-DP-30	TiF-DP-50
<b>Spectrally-limited pulse duration<sup>1)</sup></b>	<20 fs <sup>2)</sup>	<30 fs <sup>2)</sup>	<50 fs (<100 fs upon request)
<b>Spectrum width (FWHM)<sup>1)</sup></b>	>50 nm	>30 nm	>18 nm
<b>Tuning range</b>	800±10 nm (fixed)	770-830 nm	760-840 nm
<b>Average output power<sup>1),3)</sup></b>	>120 mW	>150 mW	>170 mW

#### General optical specifications

<b>Pulse repetition rate (fixed)</b>	90±10 MHz
<b>Pump source</b>	integrated, direct diode pump
<b>Spatial mode and M<sup>2</sup></b>	TEM <sub>00</sub> (M <sup>2</sup> <1.2)
<b>Beam diameter (1/e<sup>2</sup>)</b>	<2 mm
<b>Output polarization</b>	linear, horizontal, PER >20 dB
<b>Beam divergence</b>	<1 mrad
<b>Long-term stability<sup>3)</sup></b>	<0.5% rms
<b>Noise</b>	<0.5% rms (10 Hz to 10 MHz bandwidth)

#### Physical dimensions (L × W × H)

<b>Laser head dimensions</b>	510 × 270 × 119 mm
<b>Pump laser control unit dimensions</b>	290 × 200 × 80 mm
<b>Closed-loop chiller dimensions</b>	430 × 340 × 190 mm

#### Environmental and utility specifications

<b>Operating temperature</b>	15-30°C
<b>Relative humidity</b>	<60%, non-condensing
<b>Voltage</b>	single-phase; 100-240 VAC; 50/60 Hz
<b>Power consumption</b>	<1 kW

#### Available configuration packages<sup>4)</sup>

<b>"Basic" package (default)</b>	<ul style="list-style-type: none"> <li>- thermally stabilized body</li> <li>- SMA pulse train sync output</li> <li>- mode-lock status LED indication</li> <li>- push-button starter</li> <li>- USB 2.0 wavelength tuning via step-motor slit (via step number information and calibration)</li> </ul> PC requirements: USB 2.0 port, Windows 10
<b>"Auto" package</b>	<ul style="list-style-type: none"> <li>- thermally stabilized body</li> <li>- SMA pulse train sync output</li> <li>- mode-lock status LED indication</li> <li>- built-in spectrometer</li> <li>- single-touch wavelength tuning w. presets</li> <li>- built-in power meter</li> <li>- active output power stability locking</li> <li>- automatic mode-lock start and monitoring</li> <li>- Windows software with configurable widgets</li> </ul> PC requirements: USB 2.0 port, Windows 10

1) - when tuned to 800 nm; pulse duration is measured by the AA-10DD-12PS (Avesta) interferometric autocorrelator;

2) - with an external dispersion compensator (not included; offered separately, see APC);

3) - after 30 min warm-up with cold start, during 12-hour continuous operation under equal room temperature conditions using recommended stabilized closed-loop chiller with proper capacity and active output power locking ("Auto" package);

4) - please select one of the packages for your system; certain features may be tailored or combined differently according to specific customer requirements.

**China:** Eachwave scientific instrument Co., Ltd  
 Tel: +86-21-62209657, +86-21-54843093  
 Email: sales@eachwave.com  
 Web: www.eachwave.com

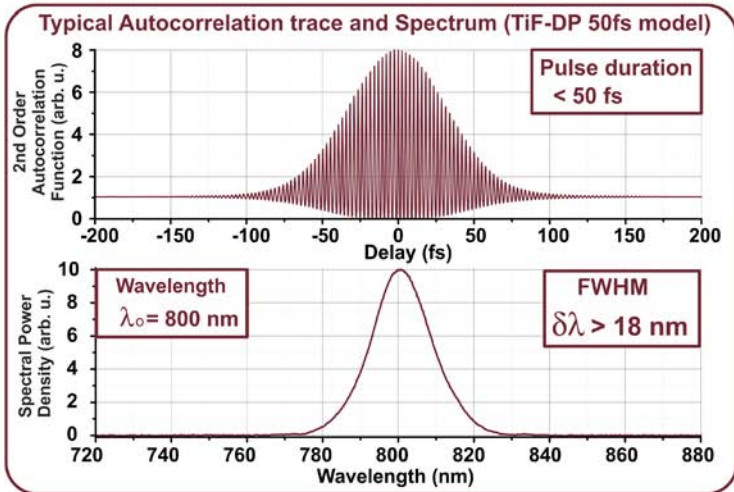
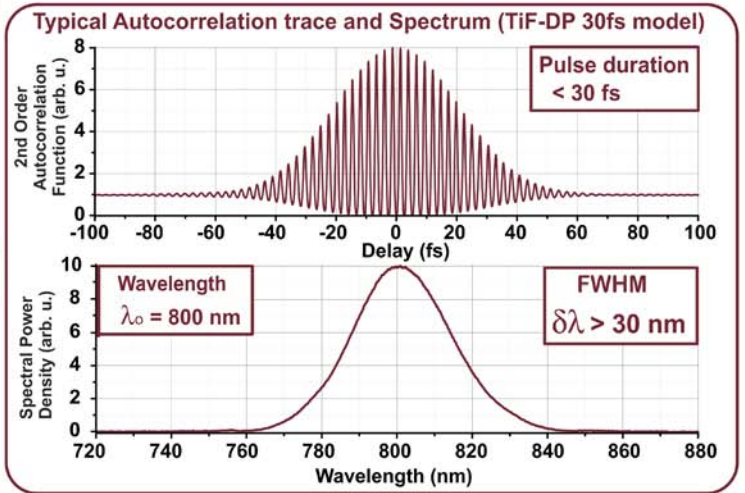
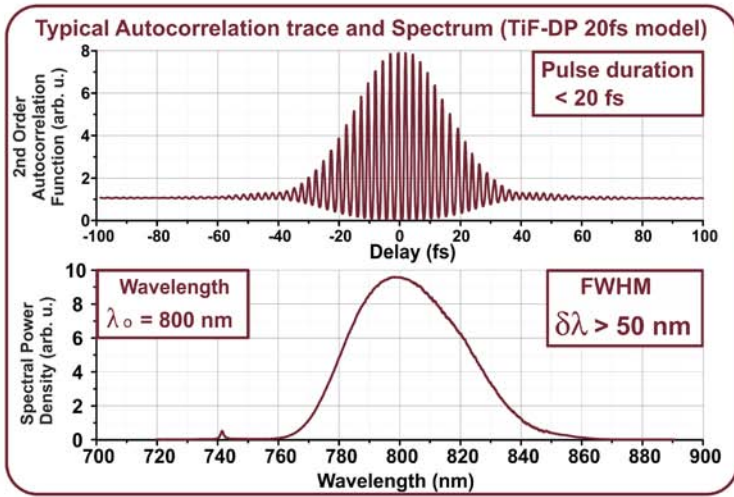

Three configurations of the TiF-DP series femtosecond Ti:S oscillator

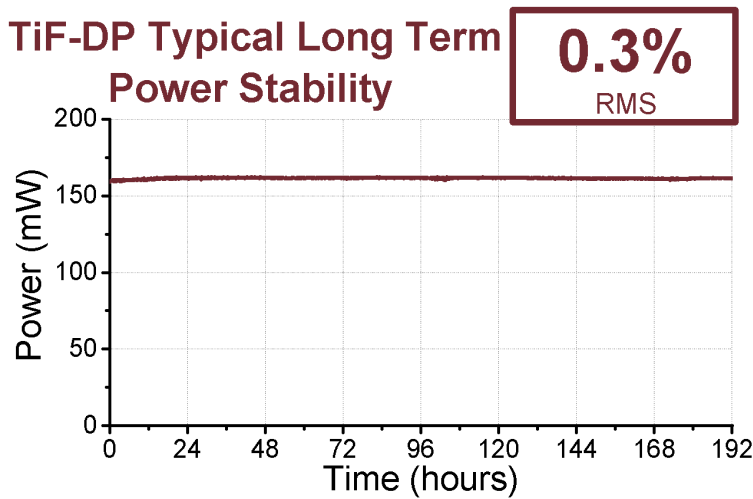

192 hours continuous stability run, acquired using an integrated pump module, at an ambient temperature of 22 degrees C, with "Auto" package and active power locking

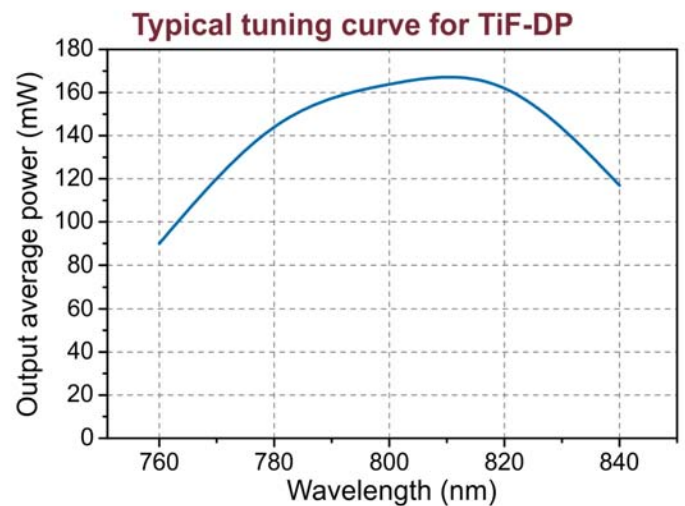

TiF-DP-50 wavelength tuning curve

China: Eachwave scientific instrument Co., Ltd  
 Tel: +86-21-62209657, +86-21-54843093  
 Email: sales@eachwave.com  
 Web: www.eachwave.com



# TiF DP optical head dimensions

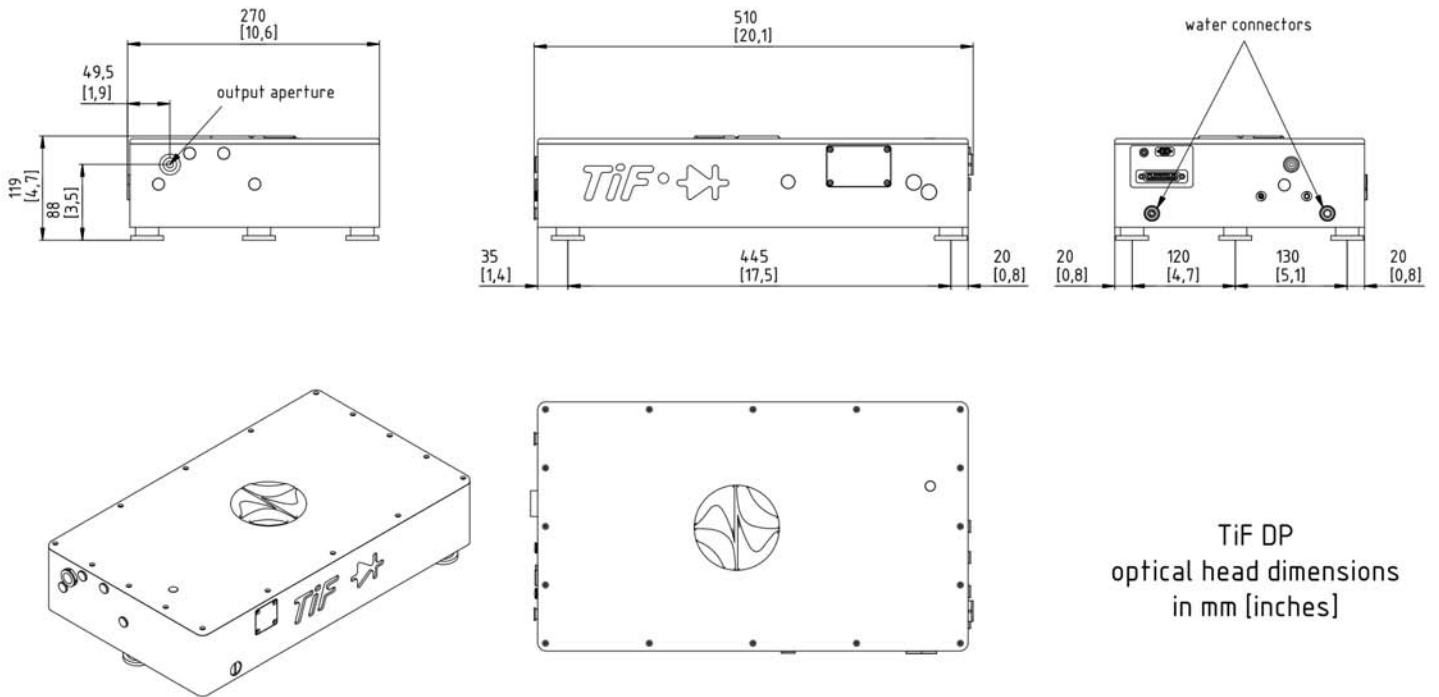

TiF DP  
optical head dimensions  
in mm [inches]

TiF-DP dimensions in mm [inch] with integrated diode pump

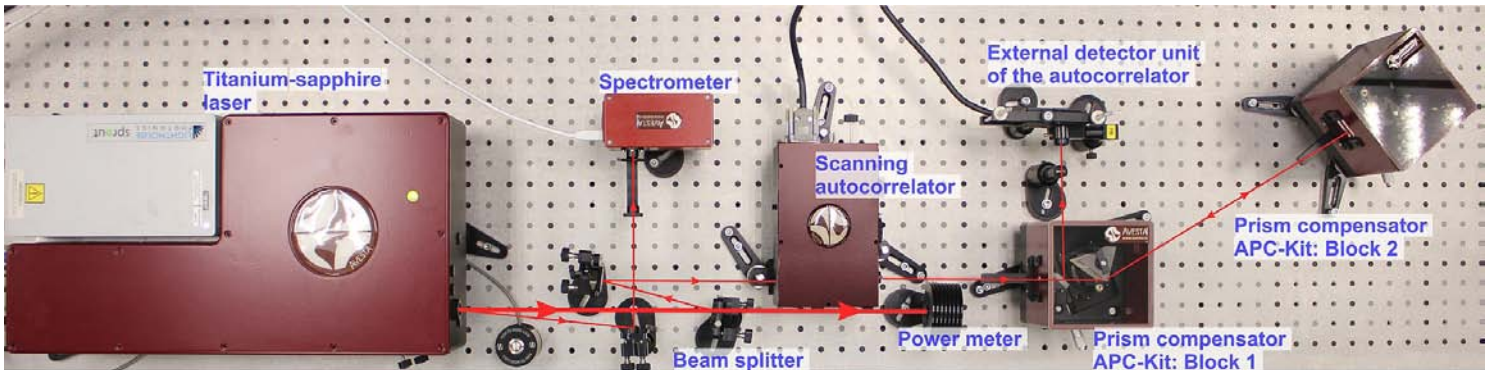

Possible total dispersion control setup for multi-photon microscopy applications with TiF Series laser, APC Kit dispersion compensator and AA-M scanning autocorrelator with an external detector unit

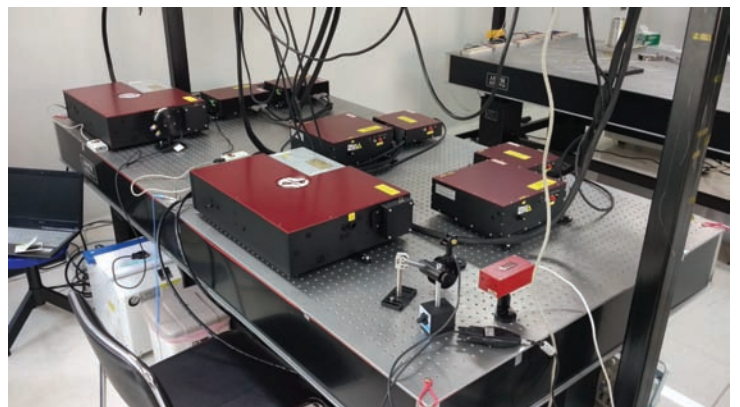

Installed TiF Series laser systems at customers' sites